

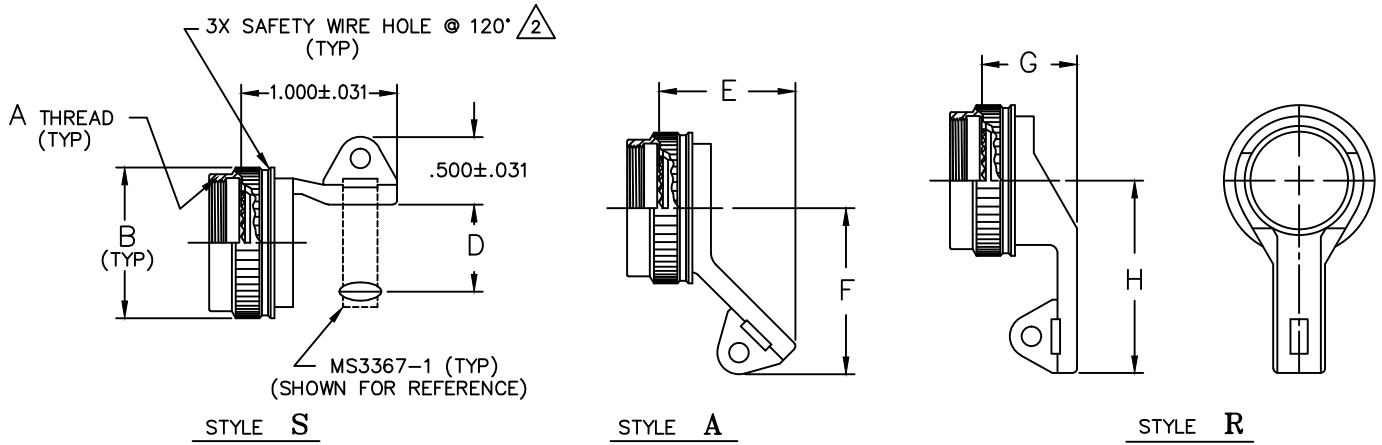

ELECTRO ADAPTER INC.
 CHATSWORTH, CALIFORNIA, USA 91311
 PHONE (818) 998-1198
 FAX (818) 709-5773

**SECTION 4 - OPEN FRAME ADAPTER
 "BAND IT" WIRE BUNDLE,
 TIE STRAP RELIEF, GROUND LUG
 MIL - DTL - 38999, SERIES I & II**

10541
 SHEET 1 OF 1



Example Part Number

10541R12G55²³⁴⁵

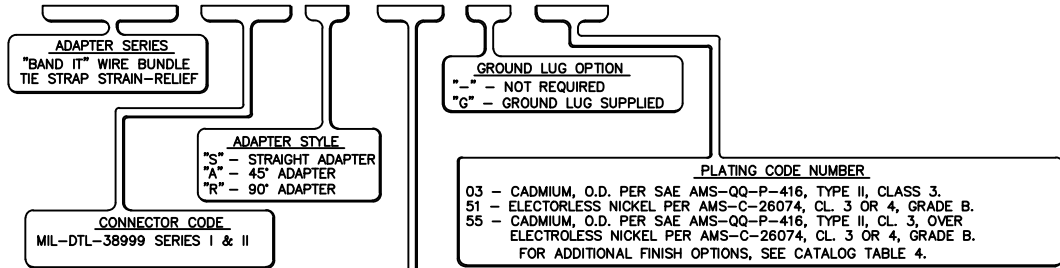

DASH NUMBER	SHELL SIZE		A UNIFIED CLASS	THD 2B	ØB MAX OD	D MAX CABLE ENTRY	E MAX	F MAX	G ±.031	H MAX
	COM'L	MIL								
0 8	8	9	M12 X 1.0		.703	.264	1.156	.875	.625	.890
1 0	10	11	M15 X 1.0		.827	.392	1.156	.875	.625	.950
1 2	12	13	M18 X 1.0		.953	.506	1.156	.938	.625	1.010
1 4	14	15	M22 X 1.0		1.077	.631	1.656	1.250	.688	1.310
1 6	16	17	M25 X 1.0		1.203	.756	1.656	1.312	.688	1.390
1 8	18	19	M28 X 1.0		1.327	.845	1.750	1.375	.688	1.470
2 0	20	21	M31 X 1.0		1.453	.970	1.812	1.500	.750	1.510
2 2	22	23	M34 X 1.0		1.577	1.095	1.812	1.688	.750	1.570
2 4	24	25	M37 X 1.0		1.703	1.220	1.969	1.750	.750	1.640

NOTES: UNLESS OTHERWISE SPECIFIED.

1. ASSEMBLY IDENTIFICATION PER MIL-STD-1285.
- ² ADD 'W' IN PART NUMBER FOR COUPLING NUT WITH WIRE HOLES. OMIT 'W' IF NOT REQUIRED.
- ³ ADD 'L' IN PART NUMBER FOR SELF-LOCKING COUPLING NUT.
- ⁴ ADD 'V' TO END OF PART NUMBER FOR 'A' THREAD COATED WITH VIBRATITE 205.
- ⁵ ADD 'T' TO END OF PART NUMBER FOR 6-32 TAP IN GROUND LUG.